

XTOOL | M2

Quick Start Guide

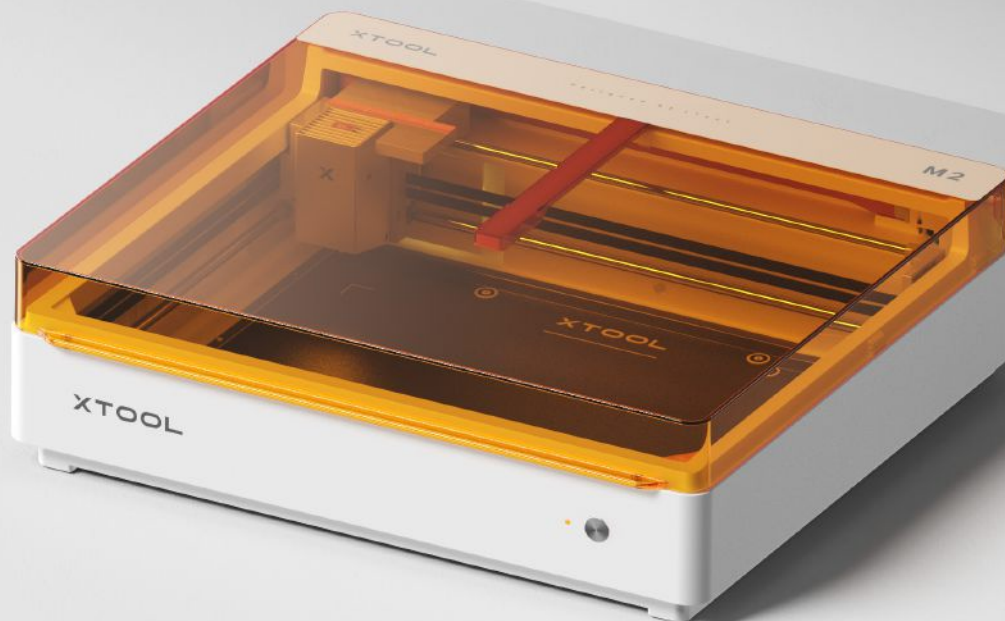

List of items	01
Meet your xTool M2	03
Preparations	04
Use xTool M2	14
Secure the material	15
Understand the indicator and Start/stop button	20
Maintenance	22
Use xTool M2 CMYK Inkjet Module with xTool M2	30
Use xTool Rotary Attachment 3 Lite with xTool M2	30

List of items

xTool M2

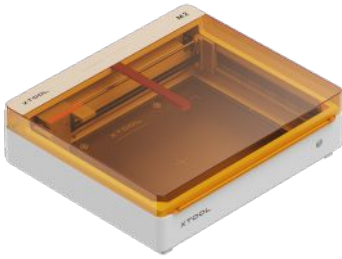

xTool M2



Module connection cable



Power adapter and cable



USB cable and adapter



Smoke exhaust pipe



Clamp



Grease

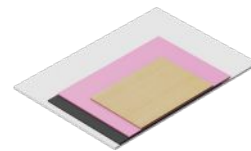

Material pack



Magnetic fixture



Hex screwdriver



Masking tape



Screw M3*6



Instruction card



Safety Instructions

Laser module



xTool M2 CMYK Inkjet Module



xTool M2 CMYK Inkjet Module



Ink cartridge



Bottom cap



Moisturizing liquid



Bottom cap retainer plate



Screw



Calibration card (A5)



Ferrite core



User manual

xTool Rotary Attachment 3 Lite

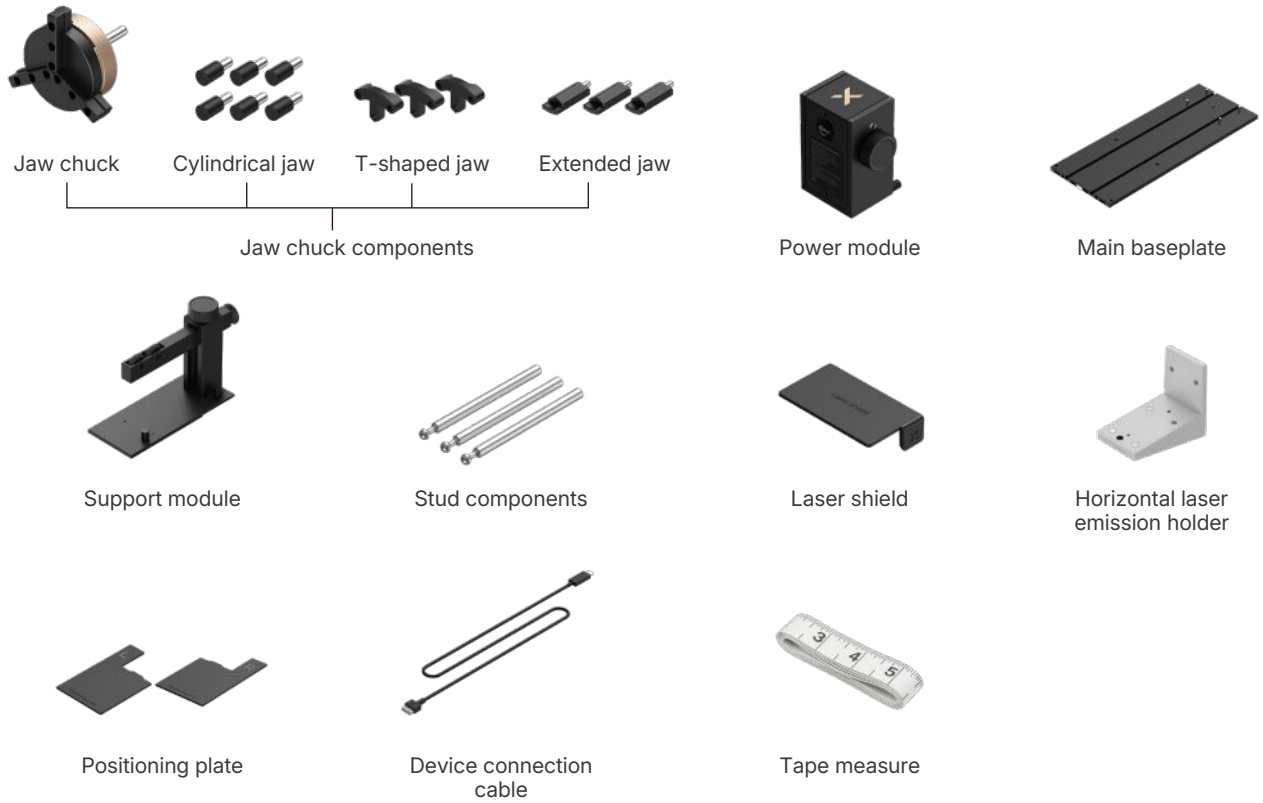

	xTool M2	Laser module	xTool M2 CMYK Inkjet Module	xTool Rotary Attachment 3 Lite
Basic kit	✓	✓		
Colorful bundle	✓	✓	✓	
Deluxe bundle	✓	✓	✓	✓



The adapter, power cable, USB cable and adapter, and material pack may vary according to kits. The illustrations are for reference only.

Meet your xTool M2

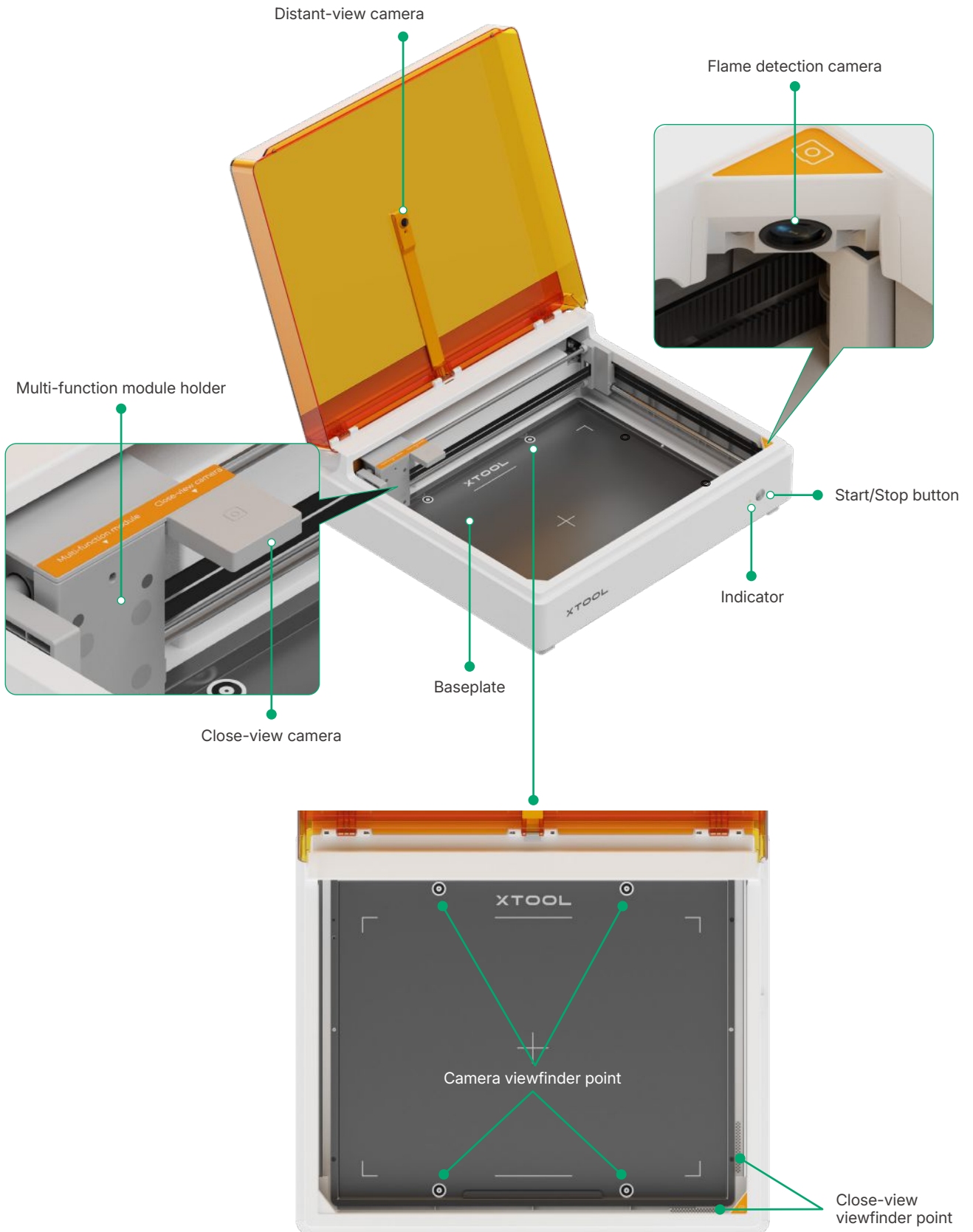

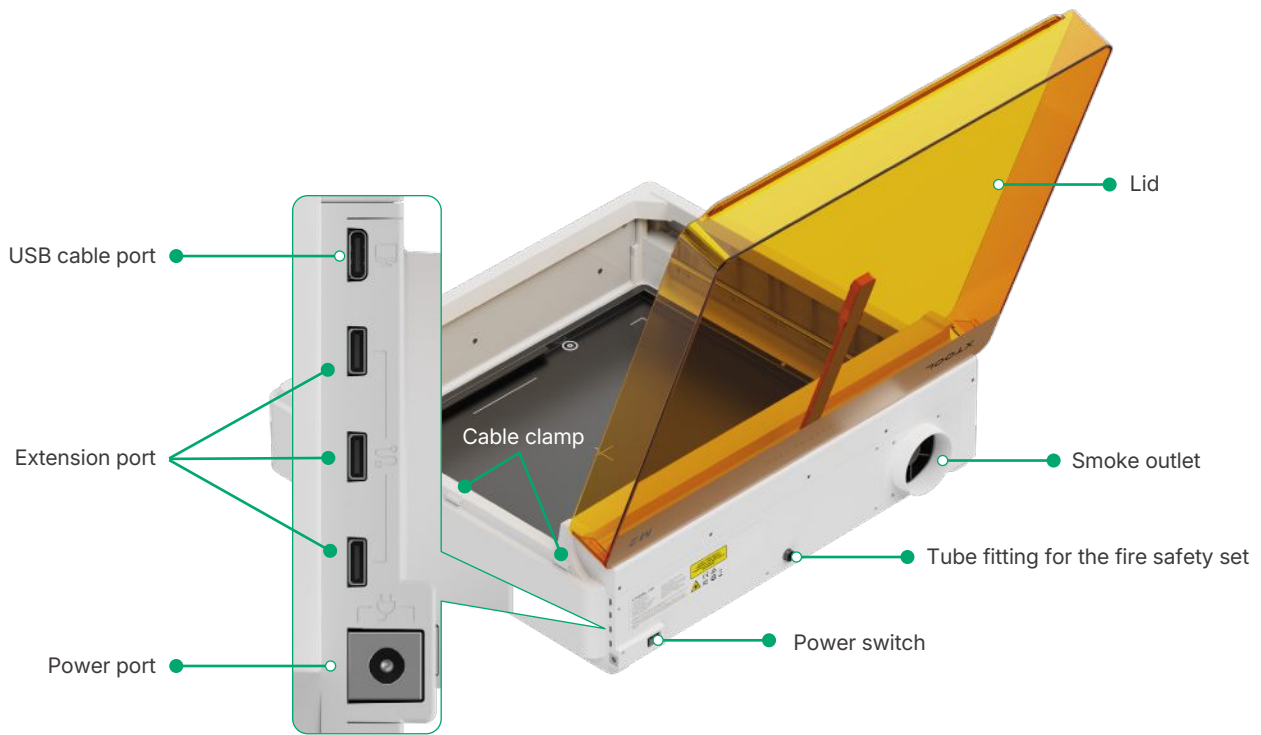

Preparations



It is recommended that you place the device on a stable and flat work surface.

1 Open the lid, and take out the foams and items inside the device

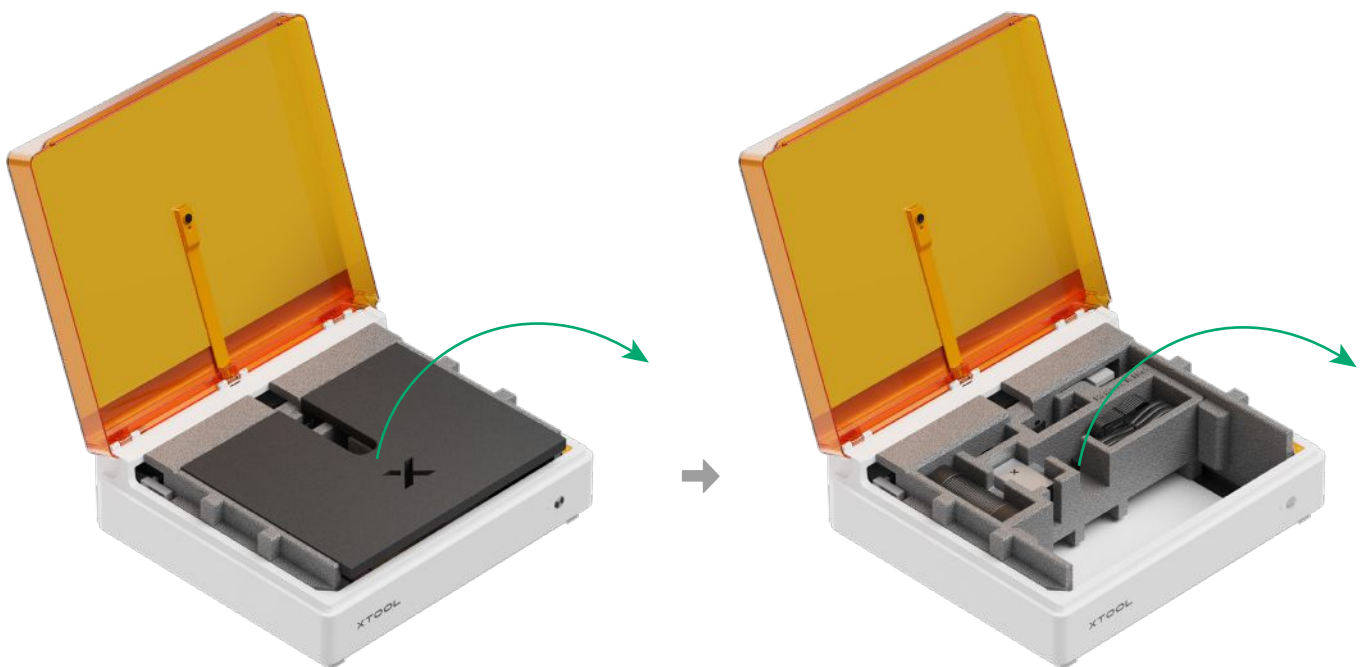

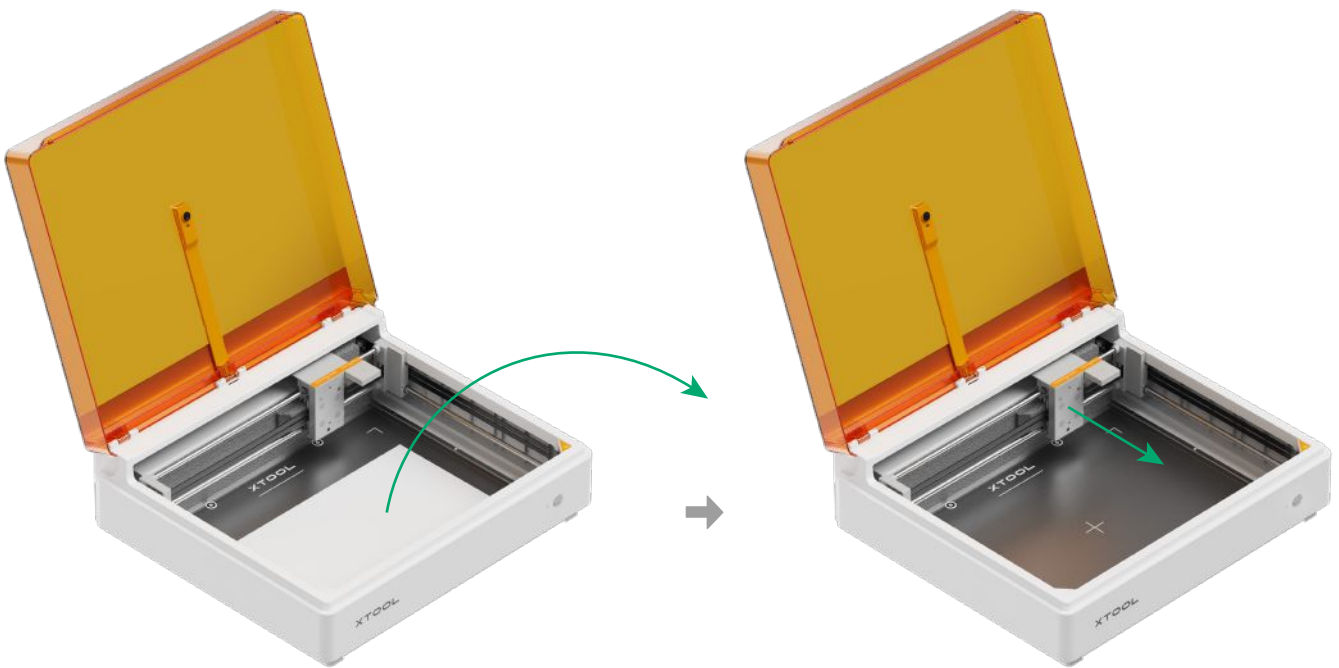
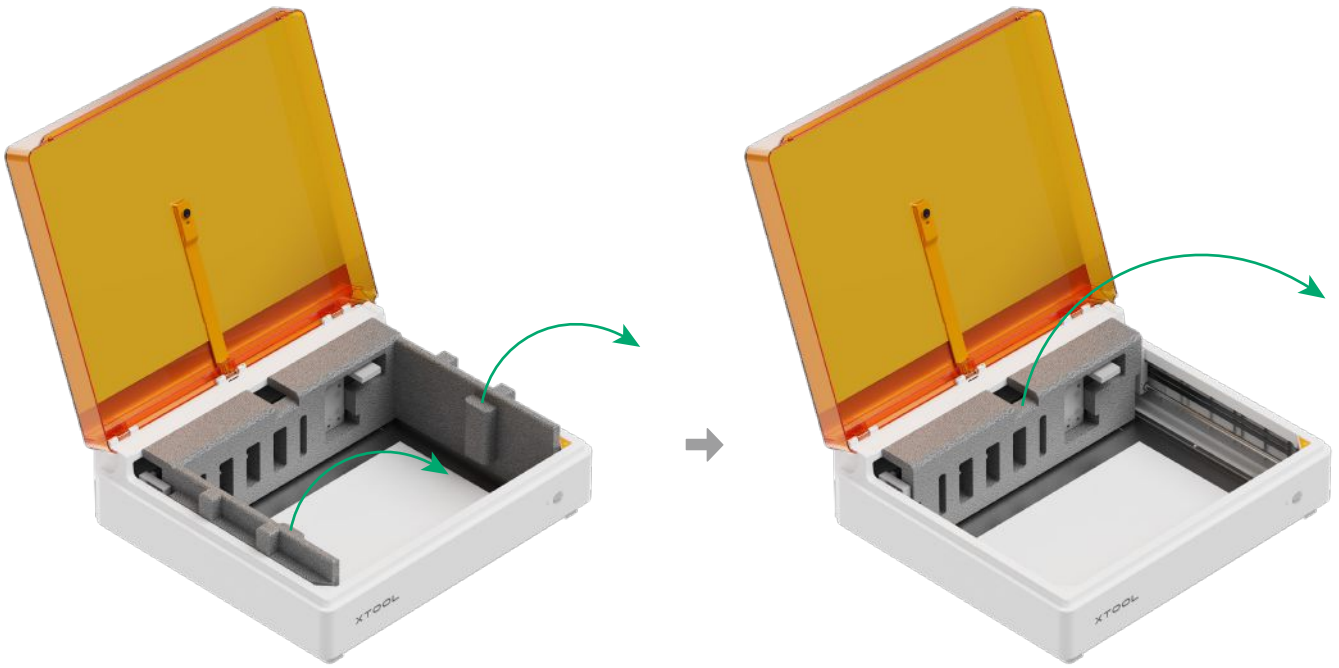

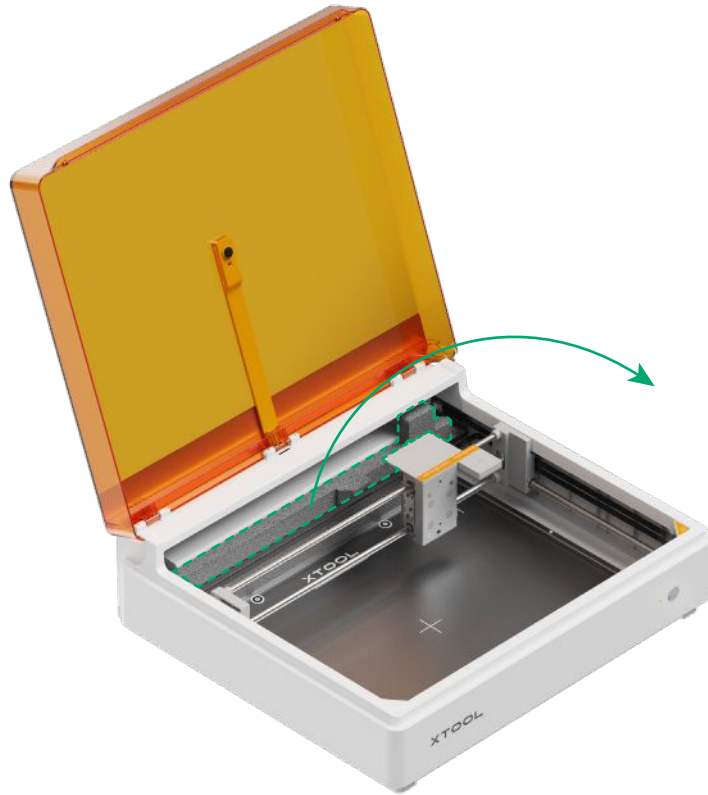

2 Apply grease to the front and rear linear shaft of the laser module

(1) Pull down the module holder plate with one hand, and apply grease thoroughly to the front linear shaft.



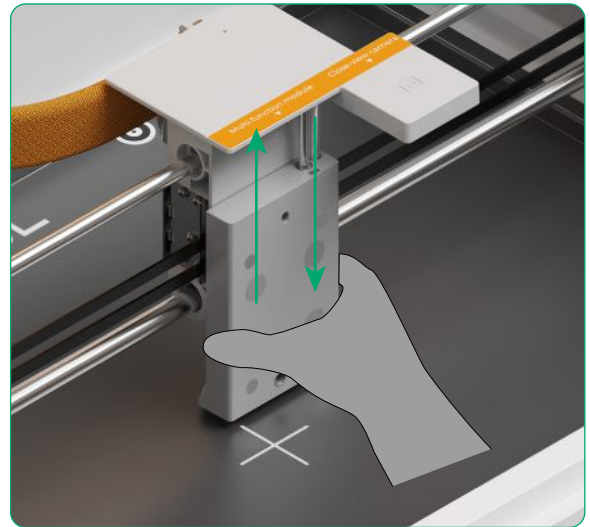
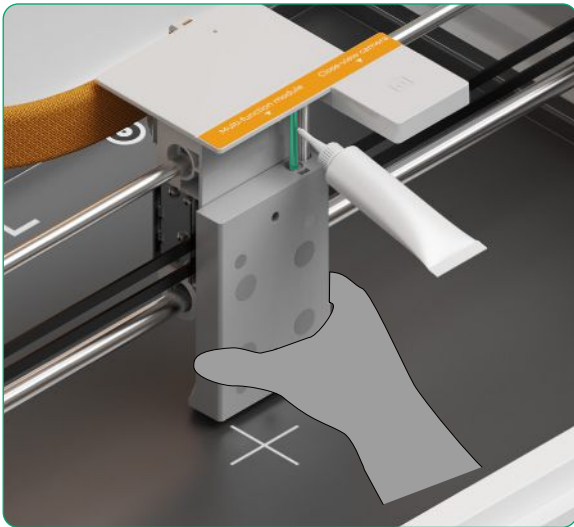

When applying grease to the front linear shaft thoroughly, pull the module holder plate all the way down, and release your hand. Repeat this action three times.

(2) Apply grease thoroughly to the rear linear shaft in the same way.

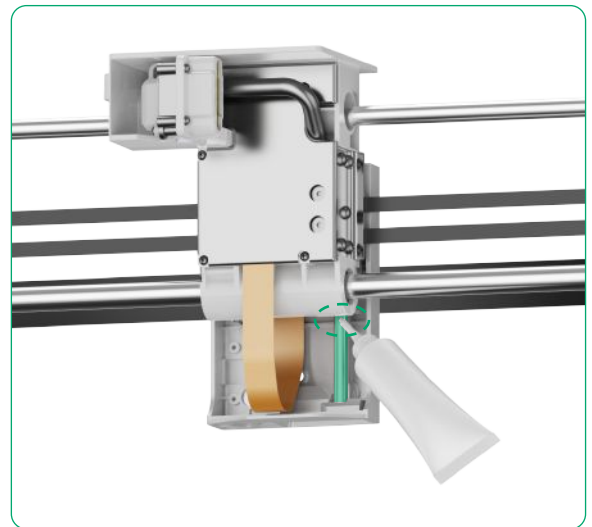

The top of the rear linear shafts must be completely coated with grease.

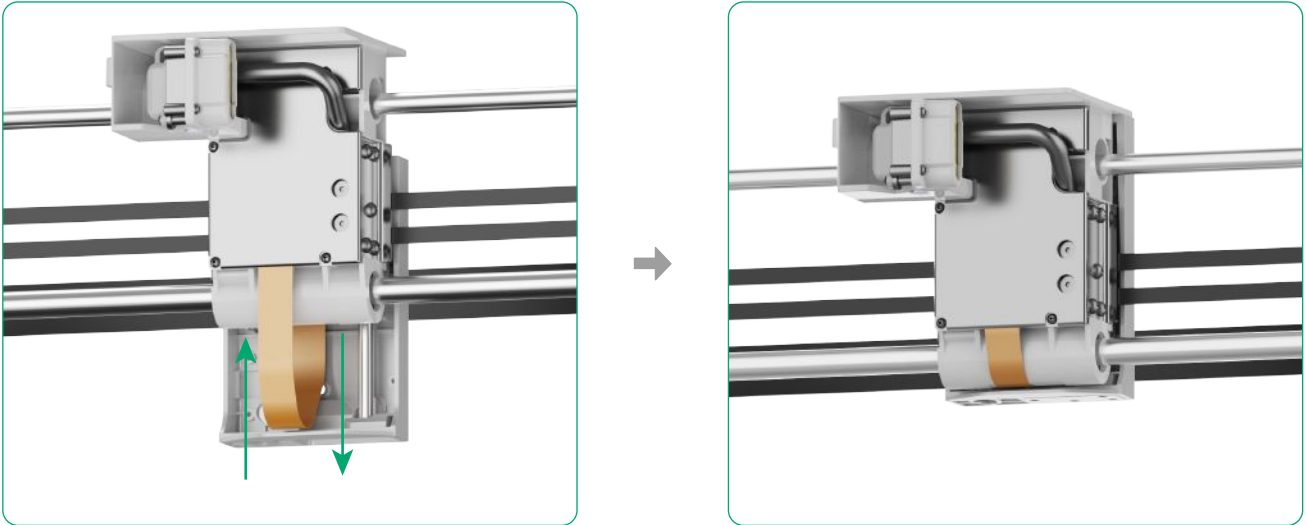

When applying grease to the rear linear shaft thoroughly, pull the module holder plate all the way down, and release your hand. Repeat this action three times.

3 Install the smoke exhaust pipe

(1) Loosen the latch of the clamp, and install it on the smoke exhaust pipe.

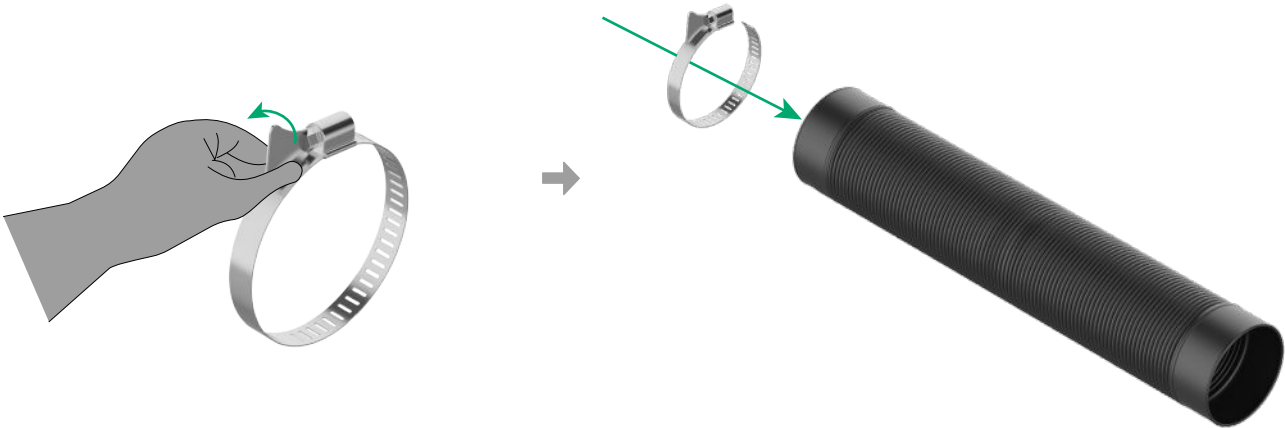

(2) Install the smoke exhaust pipe and tighten the latch of the clamp.

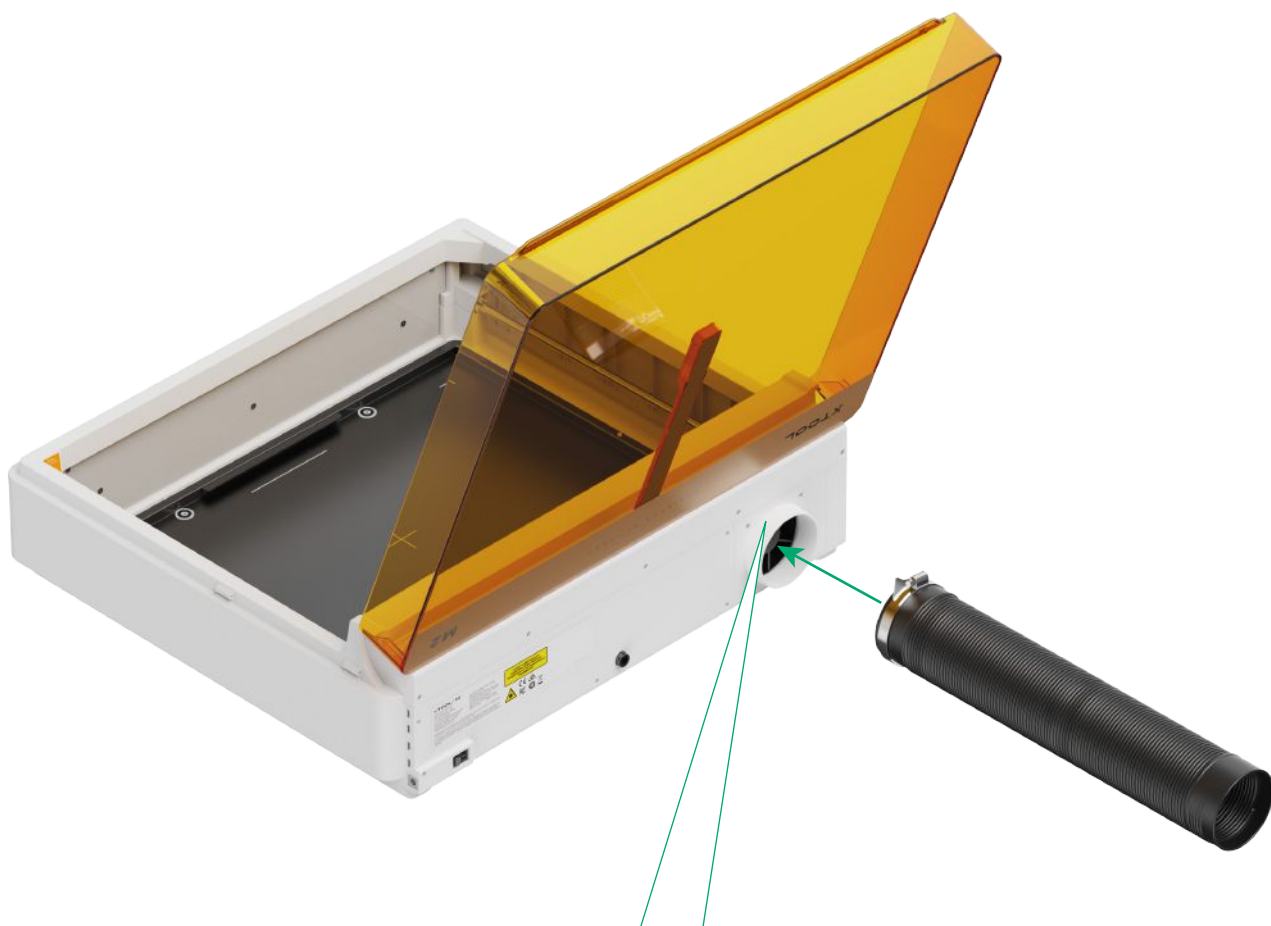



The device may produce harmful smoke and dust or gas during processing. It is recommended that you install the smoke exhaust pipe and connect it to the air purifier or place the smoke outlet out of the window.

Exhaust the smoke through the air purifier

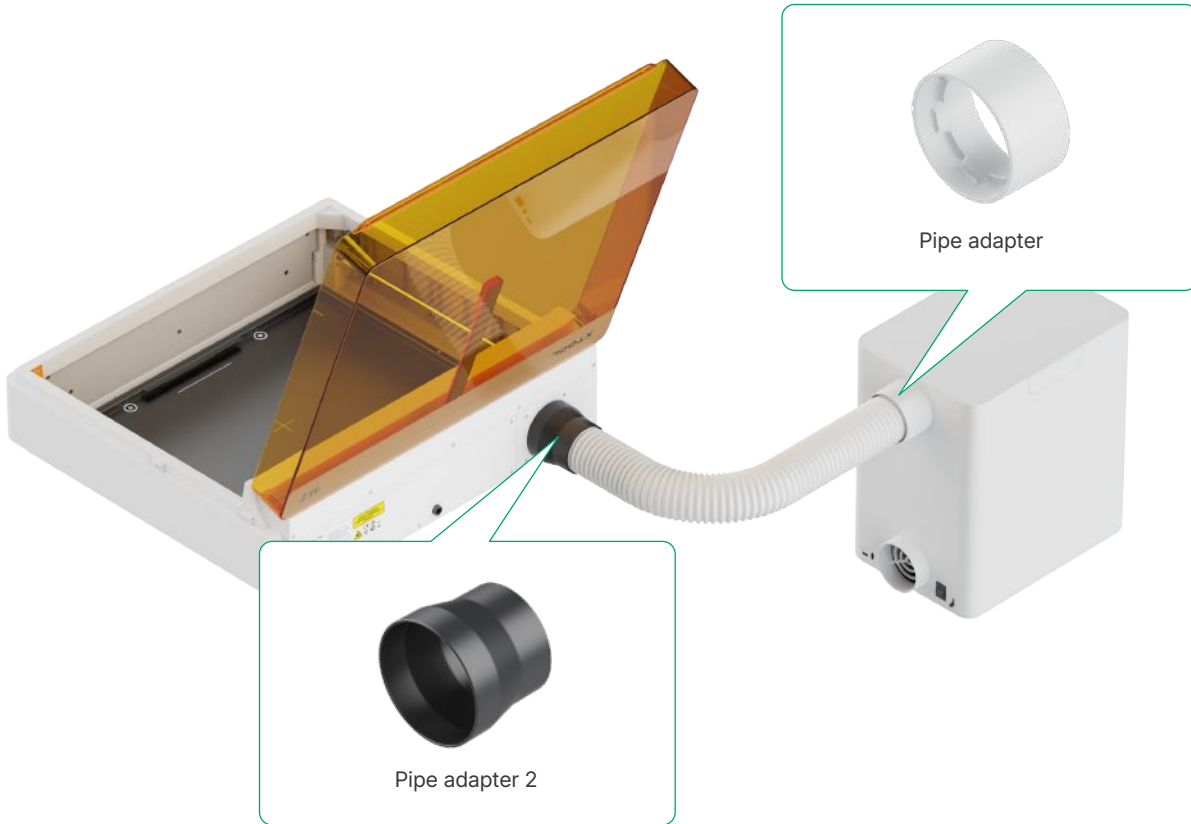

If you have purchased the desktop smoke purifier, go to support.xtool.com/replacement-parts?from=support_home apply the pipe adapters.



To know more details about xTool SafetyPro™ AP2, visit support.xtool.com/product/53.

Exhaust the smoke through the window



4 Install the laser module

(1)

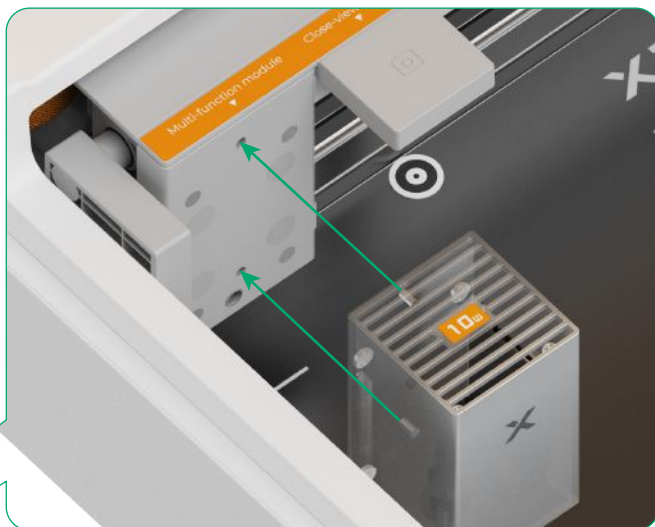

When you install the laser module, the two location pins on its back and the multi-function module holder should be aligned.



(2)

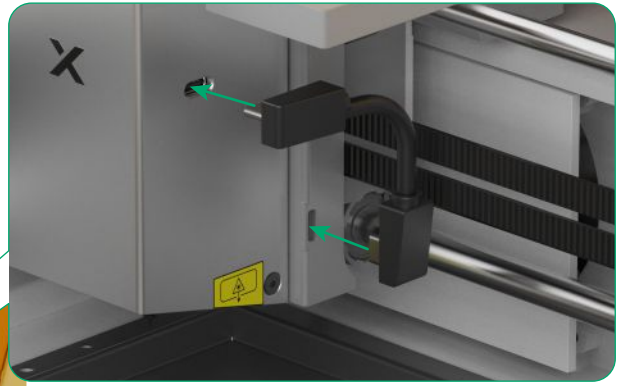
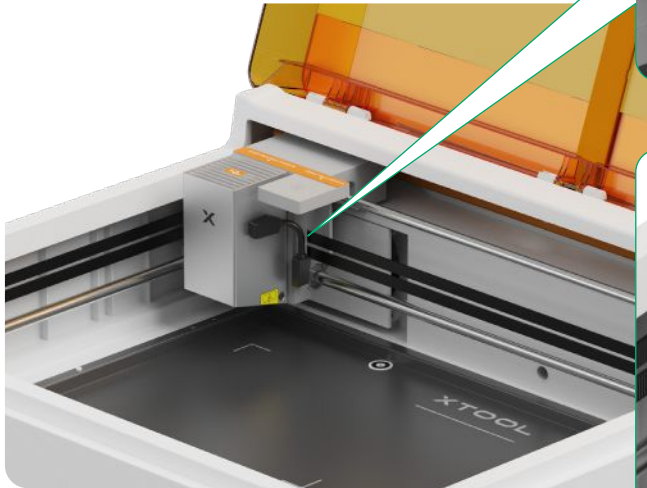
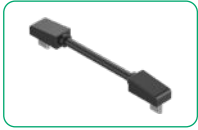

Ensure the connection cable is positioned close to the laser module.

5 Connect to a power supply and turn on the power switch

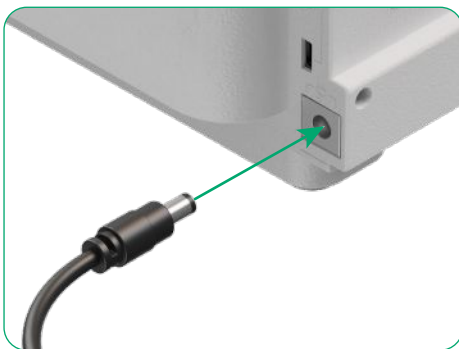
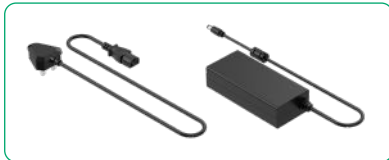

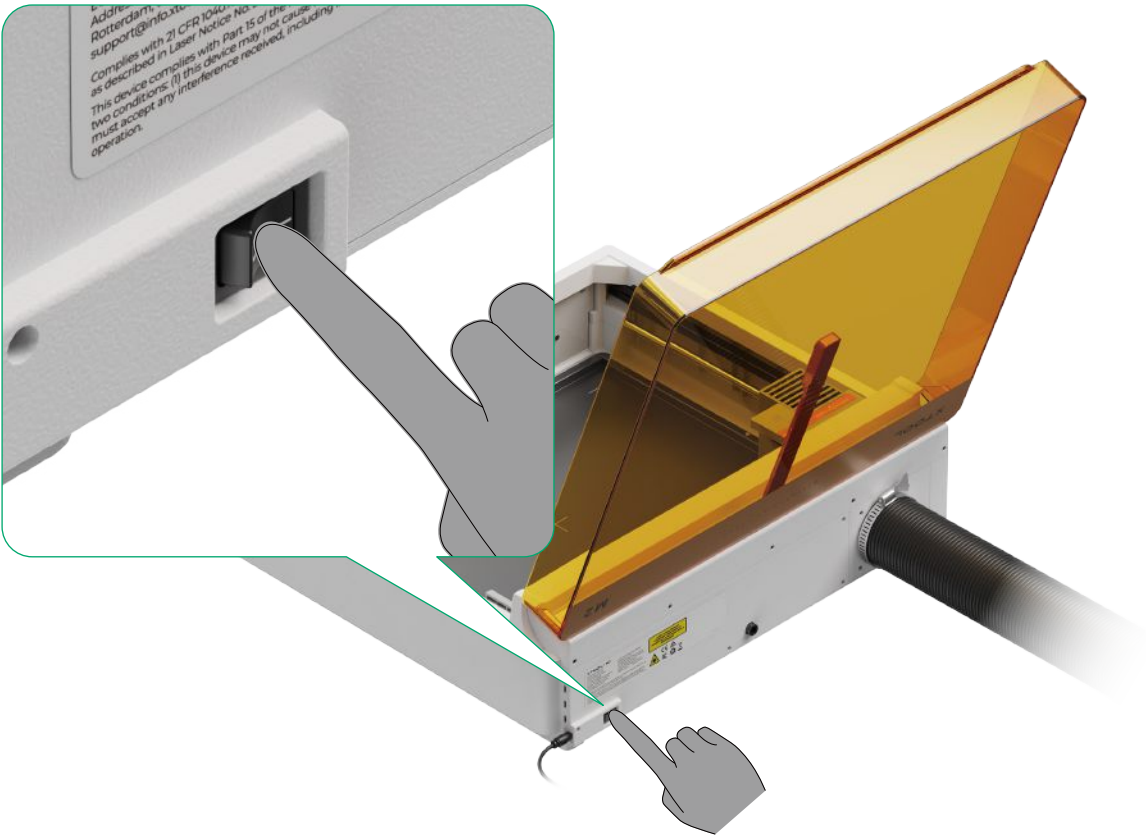

Use xTool M2

1 Get the xTool software



Go to s.xtool.com/software to get the xTool software

2 Connect xTool M2 to your computer

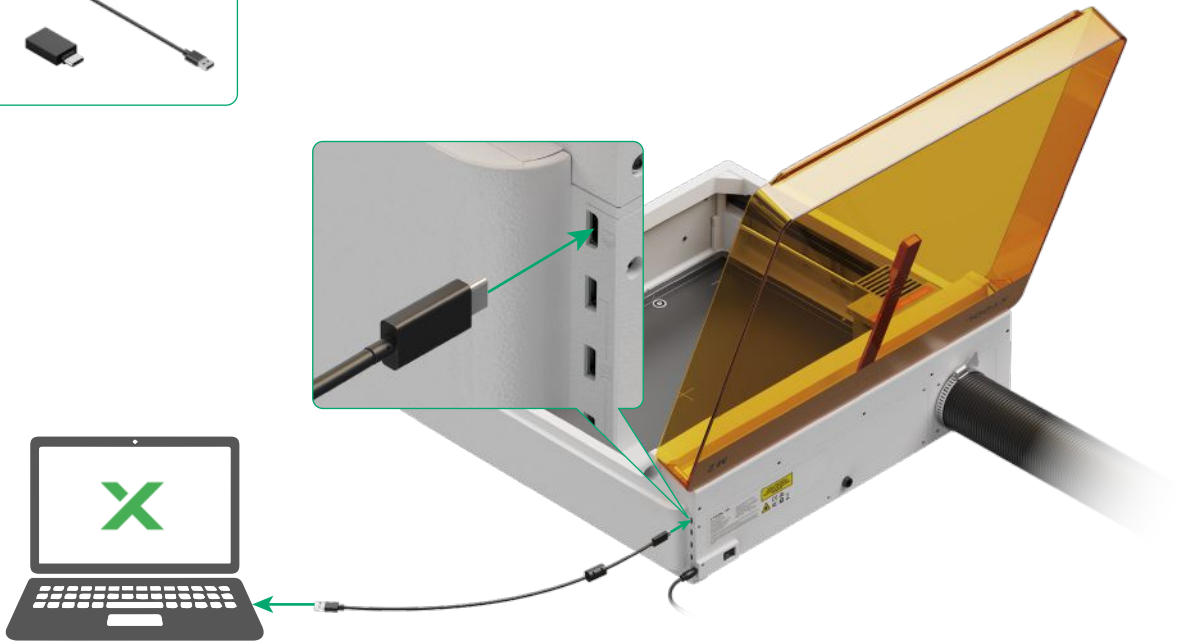
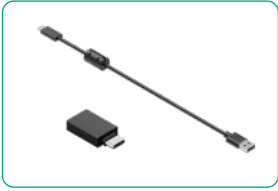

For more details about using xTool M2 with the software, visit support.xtool.com/article/2807.
For more details about the software and projects, visit support.xtool.com/academy

Secure the material



Before securing the material, clean the baseplate to ensure its surface is smooth and level. This prevents material bulging or staining caused by debris or stains on the baseplate.

Inkjet printing or laser engraving $0 < H \leq 1.5$ mm materials: secure with masking tape



1

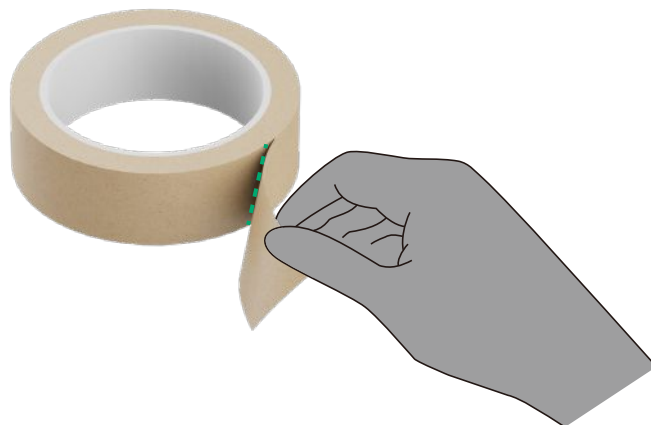

2 Secure the material on the baseplate with the masking tape

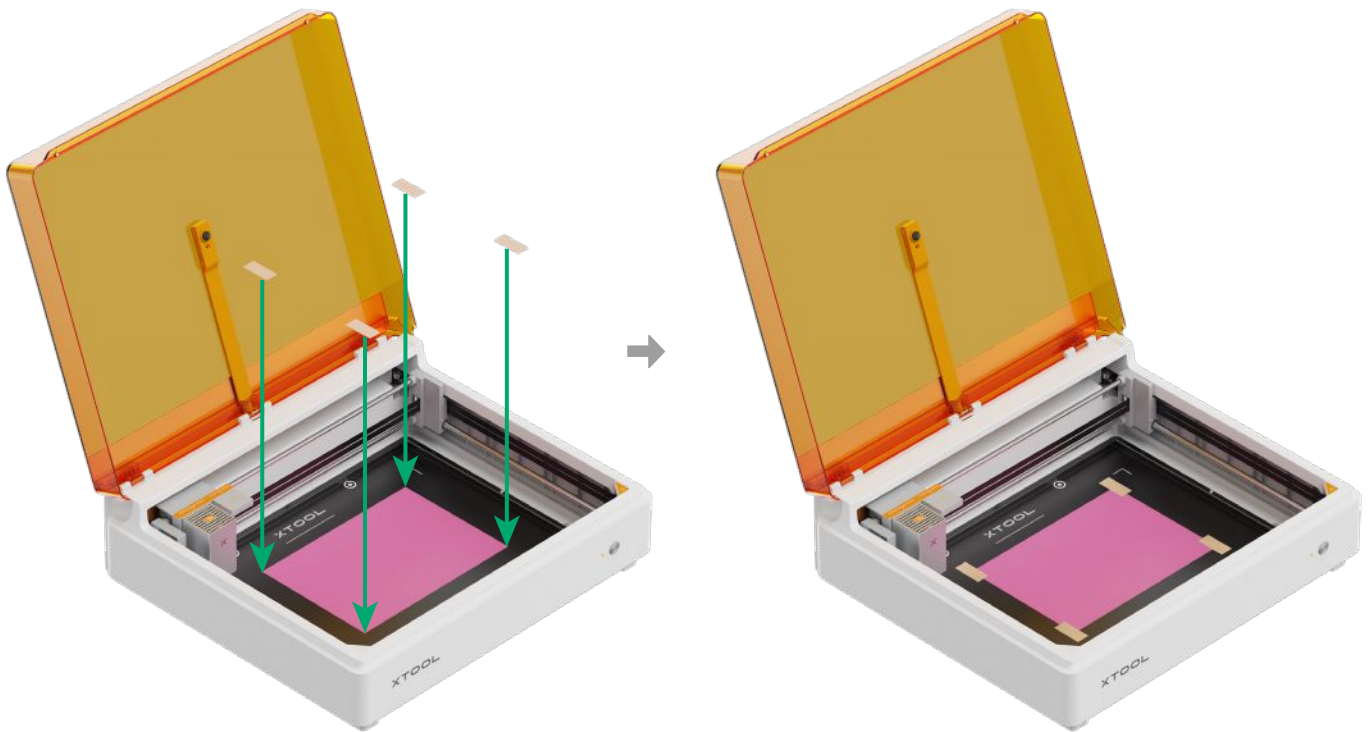

When you use the inkjet printing, regardless of the thickness of the material, it is recommended that you secure the material with tape to prevent the inkjet module from colliding with the material.

Laser cutting $0 < H \leq 6$ mm materials: secure with magnetic fixtures

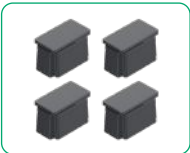

- To ensure better cutting results, lift the material with four magnetic fixtures. It provides sufficient smoke exhausting space beneath the material.
- To cut flexible materials (such as paper, thin fabric, etc.), secure them to the baseplate using masking tape or a custom-made jig.

1

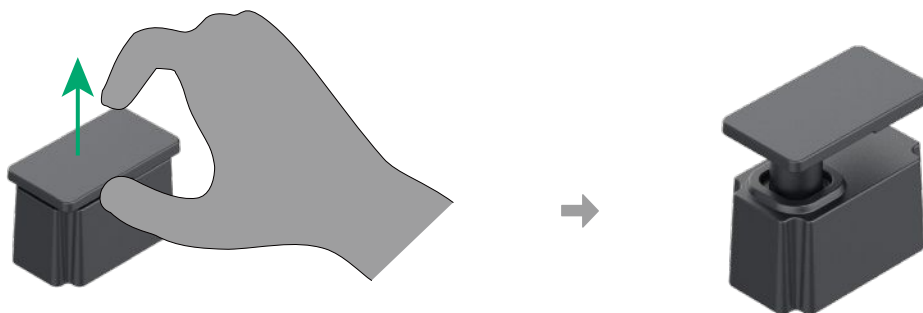

2

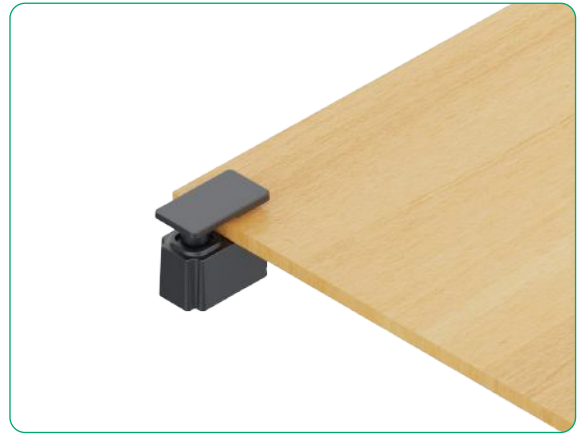
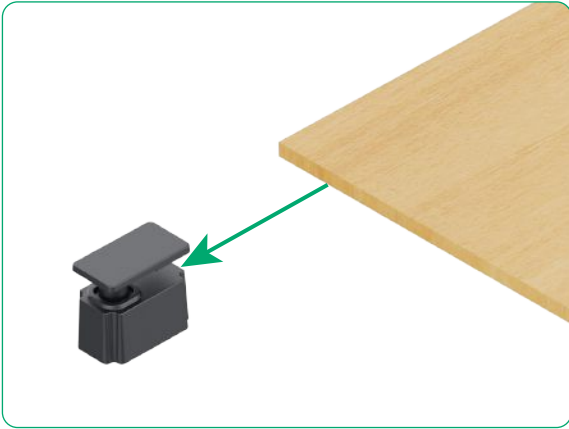

Install the other three magnetic fixtures in the same way.



3

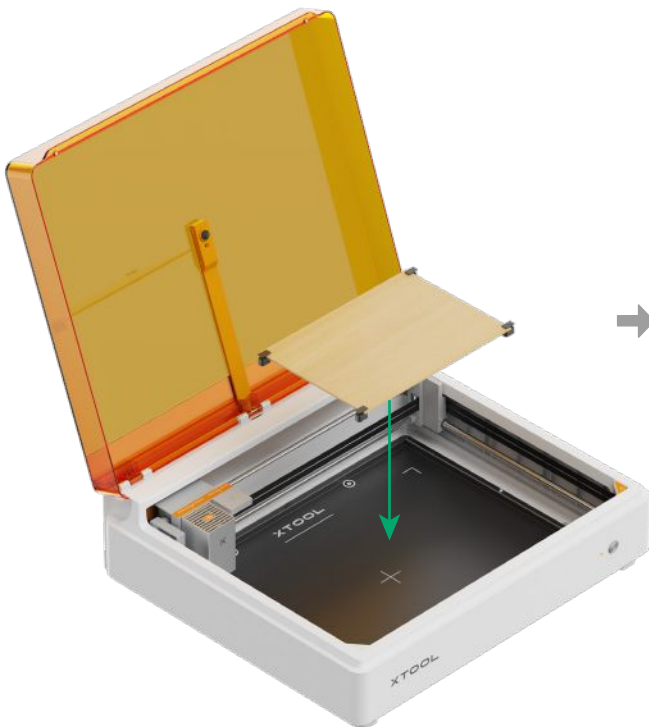



To prevent the laser module from hitting the magnetic fixtures, ensure that the edges of the processing objects maintain a distance of at least 5 mm from the magnetic fixtures.

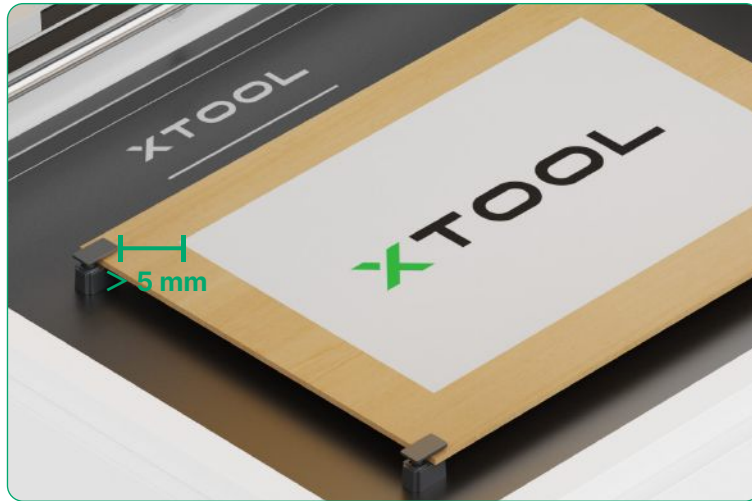

Laser cutting $6 \text{ mm} \leq H \leq 16 \text{ mm}$ materials: secure with magnetic fixtures

1

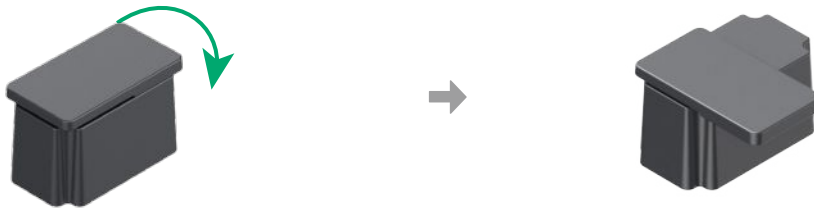

2

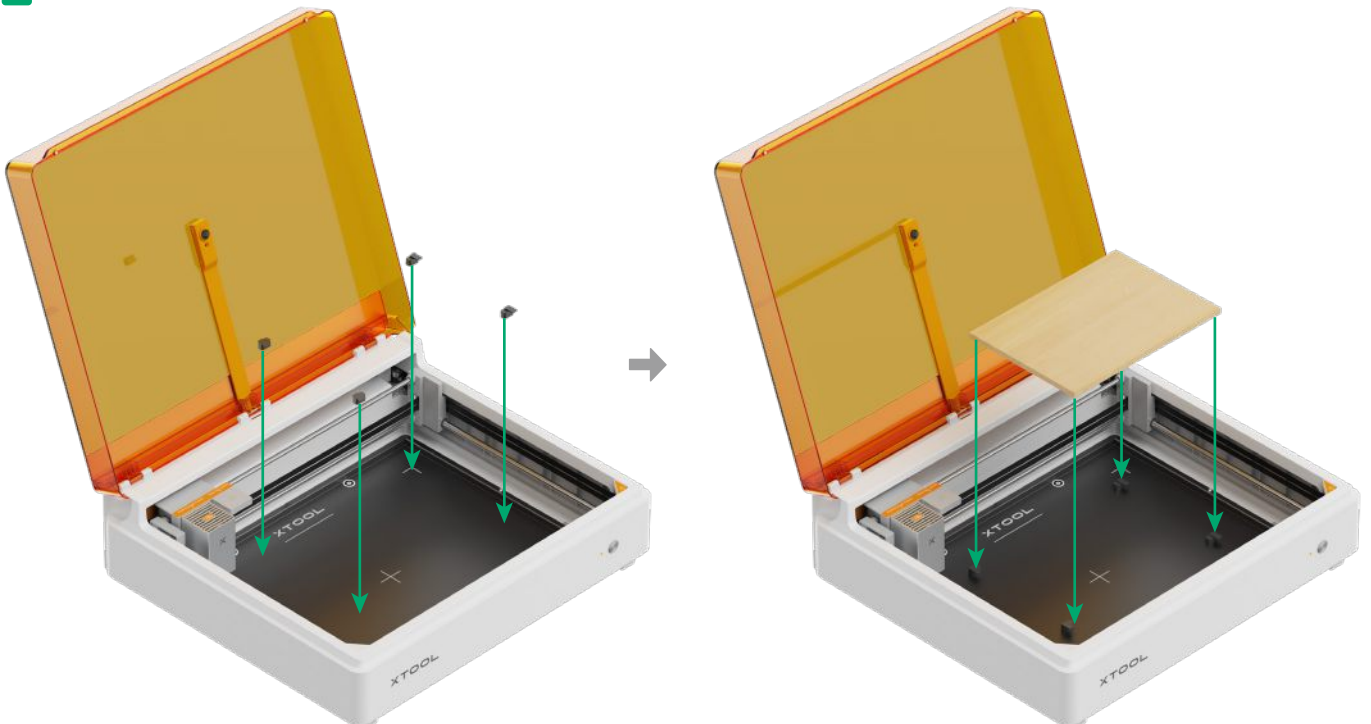



Do not put the material to be processed on the upper surface of the magnetic fixture.

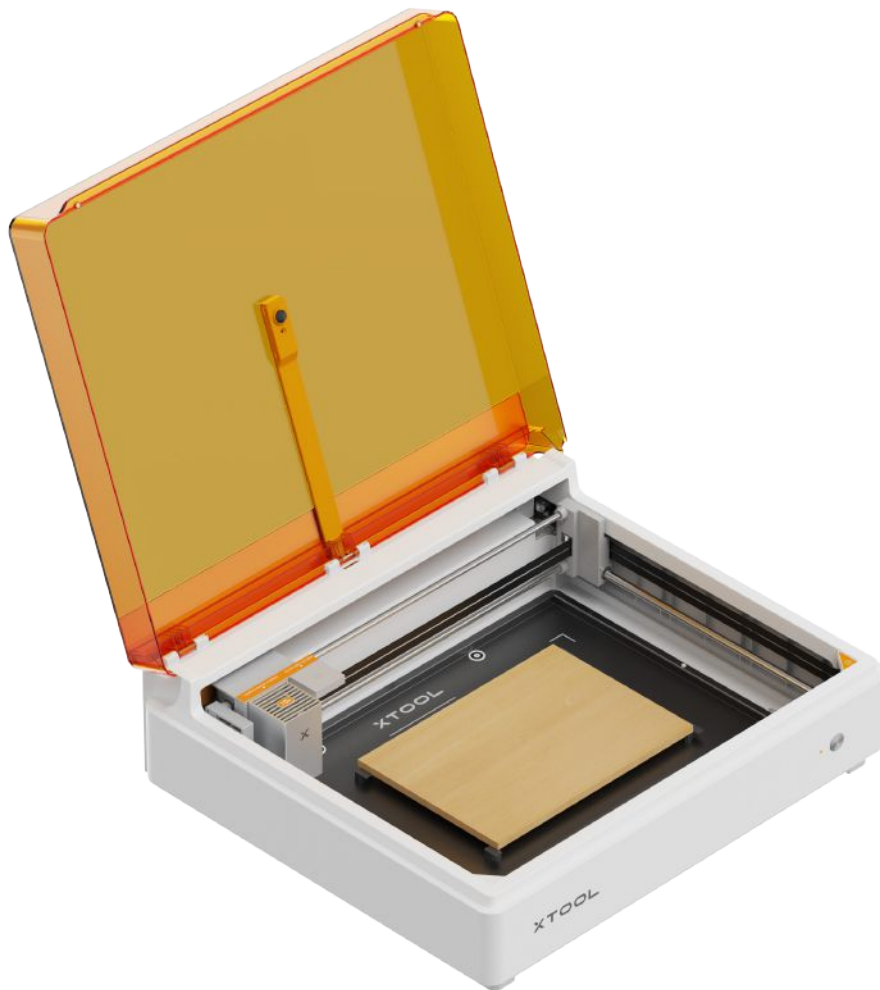

Laser engraving curved materials

To ensure accurate distance measurements, use masking tape or a custom-made jig to secure the material to the baseplate.

Understand the indicator and Start/stop button

Understand the indicator

Buzzer status	Indicator status	Device status
/	Blinking white slowly	Initializing
/	Breathing white	Sleep mode
/	Blinking blue	Configuring network
/	Solid blue	Standby, the device is not connected to the software
/	Blinking yellow slowly	Framing
/	Solid yellow	Focusing
/	Solid yellow	Automating
/	Blinking green slowly	Processing
/	Solid green	Processing paused
/	Solid purple	Firmware updating
/	Blinking purple slowly	Calibrating
Sounding once	/	Lid closed
Sounding once	Solid white	Standby, the device has connected to the software
Sounding once	Solid green	Ready to work
Sounding three times	/	Exception occurs
Keeping sounding	Blinking red quickly	Secondary and tertiary flame exceptions detected

Understand the Start/stop button operation

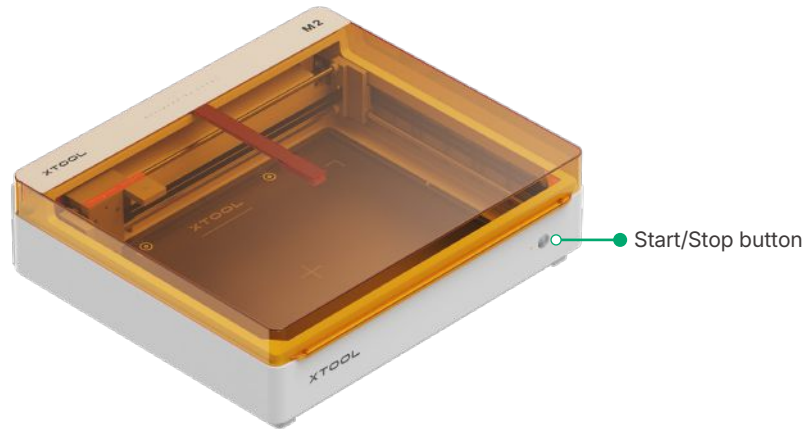

Device status	Short press button status	Long-press button status	Double-press button status
standby	/	/	Perform offline processing
standby	/	Enter the network configuration	Perform offline processing
Enter sleep mode	Activate the device, and the fill light turns on	Activate the device, and the fill light turns on	Activate the device, and the fill light turns on
Configure network	/	Exit the network configuration	/
Enter automation	/	Exit automation	/
Start framing	/	Exit framing	/
Ready for processing	Start processing	Cancel processing	/
Processing...	Processing paused	Cancel processing	/
Processing paused	Continue processing	Cancel processing	/
Calibration	/	Cancel calibration	/

Maintenance

Maintain the device

1 Clean the baseplate

Cleaning methods



Clean the residues in the device regularly to prevent the residues from getting caught in the fan, blocking exhaust and potentially causing a fire.

(1) Power off the device, and remove the baseplate.

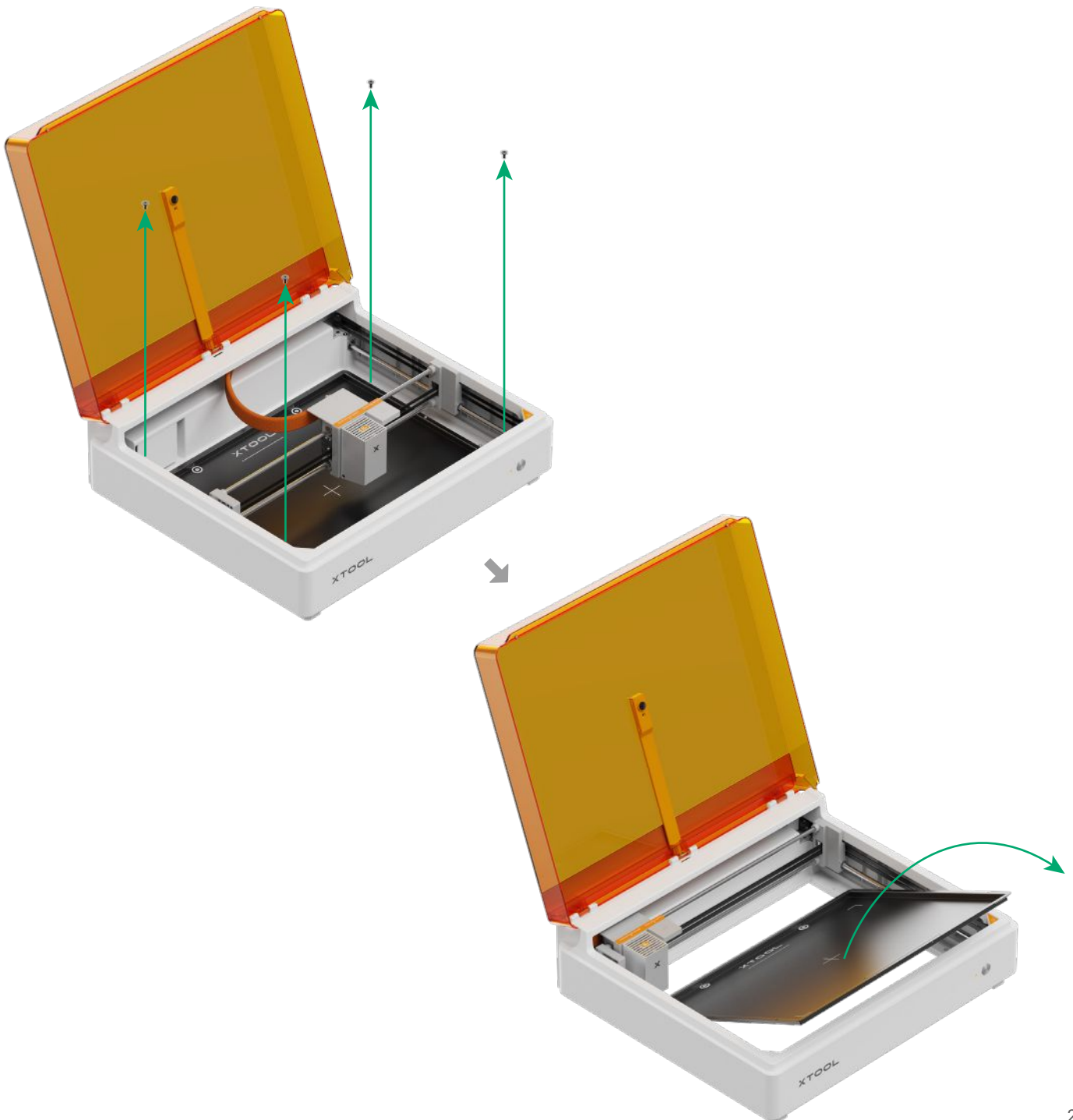

(2) Dip a cleaning cloth in dish soap and wipe the baseplate.

(3) Dry the baseplate with a dry cloth or tissue.

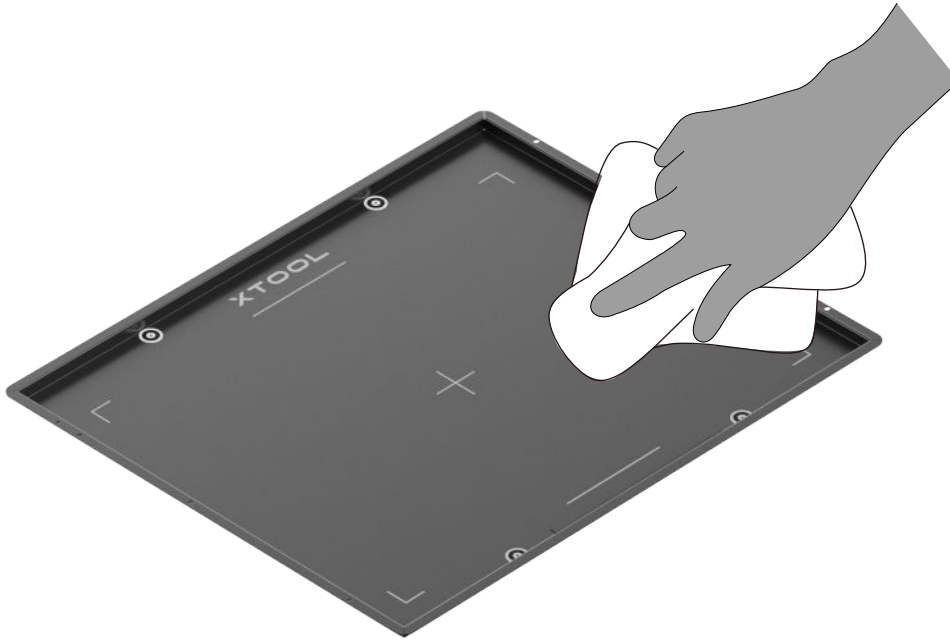

2 Clean the exhaust fan



Cleaning the exhaust fan can:

■ Maintain the cooling efficiency: Whether the exhaust fan is clean affects its rotation speed and cooling effect. Too much dust and dirt in the device will obstruct the airflow and reduce the heat dissipation efficiency, causing the device to overheat and affecting the proper operation.

■ Extend its service life: Keeping your exhaust fan clean prevents premature wear and tear. Dust and grime can cause uneven rotation, increasing wear and shortening the fan's lifespan.

Cleaning steps

(1) Turn off the device, and remove the smoke exhaust pipe and its cover.



Philips screwdriver
(not included in the pack)

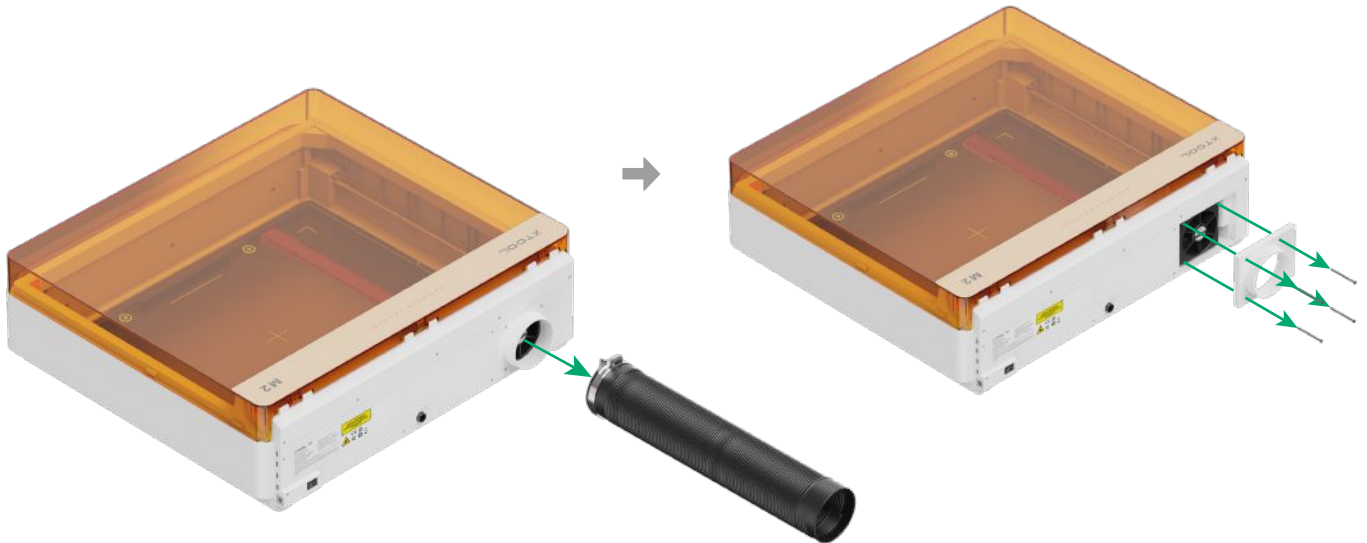

(2) Use a tissue or cotton swab moistened with clean water or alcohol to clean the fan.

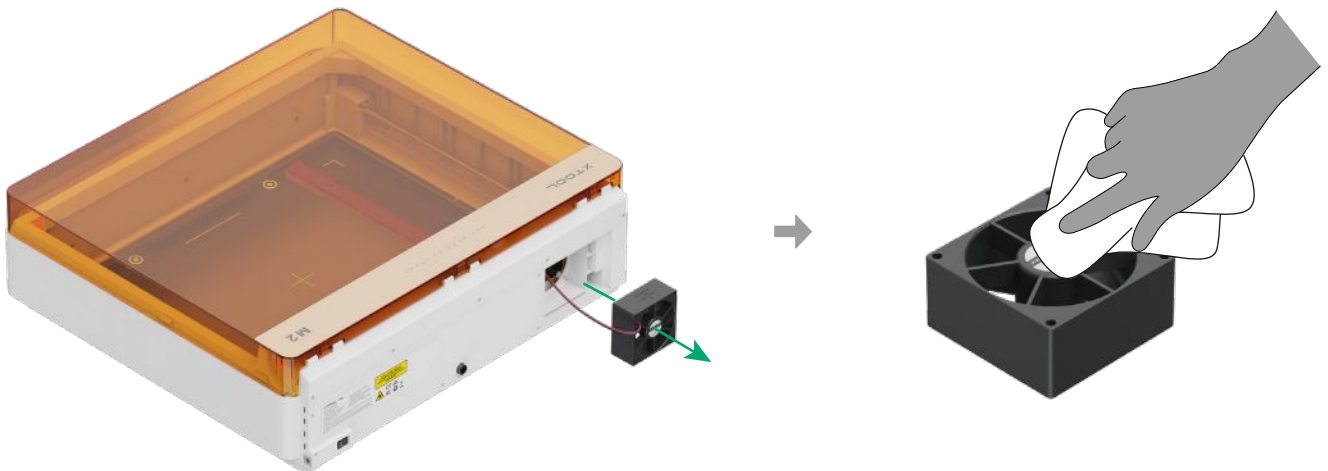

(3) Reinstall the exhaust fan according to the airflow direction mark, ensuring the airflow is directed outward from the device.

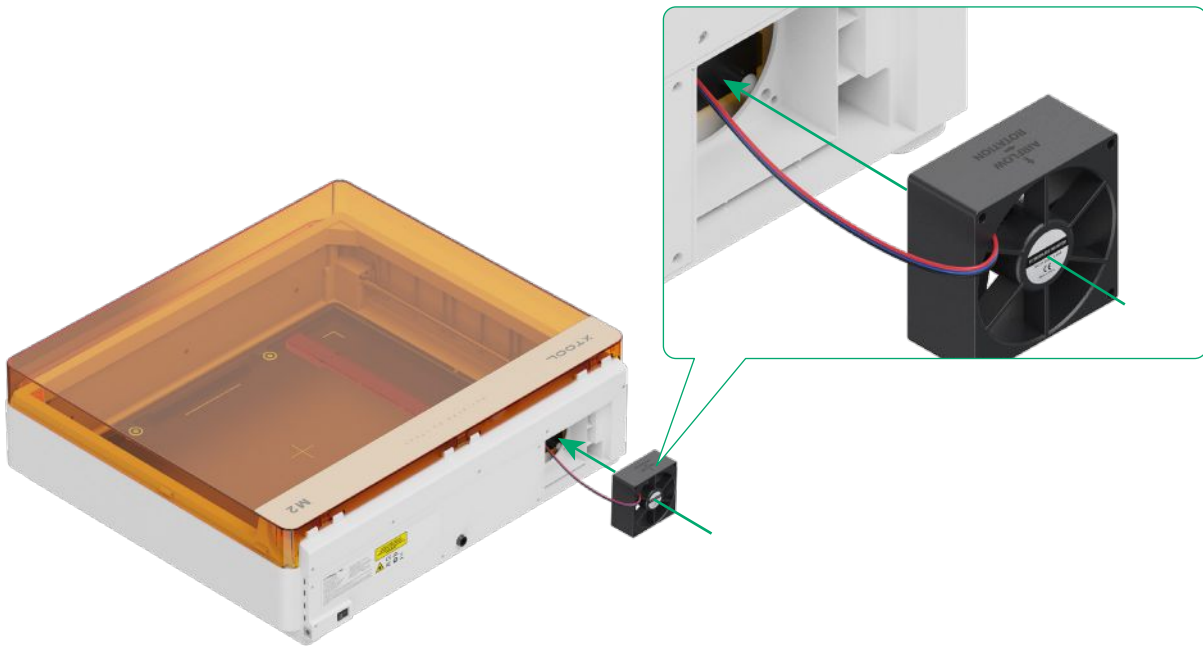

- Ensure that you disconnect the cable from the main control board during cleaning.
- Make sure to reconnect the cable securely after cleaning and avoid pulling the cable with excessive force.

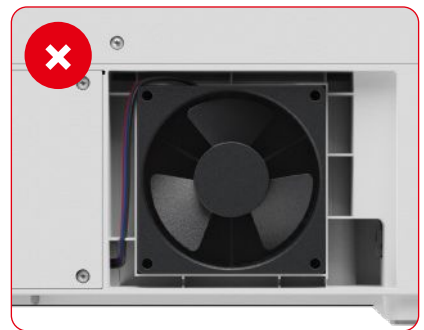
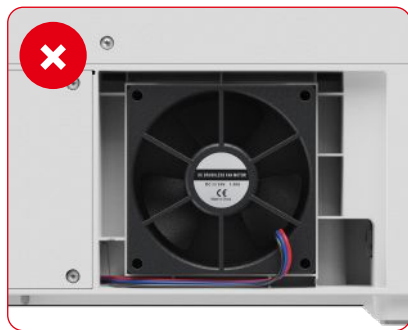
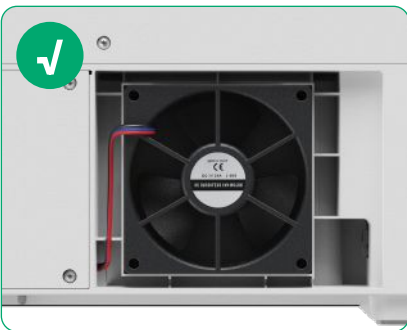

(4) Install the smoke exhaust pipe back to the device. Otherwise, laser beams may leak out, and your hands may get hurt if touching the fan.

When installing the exhaust pipe cover, hold the inner cover of the cover in place with your hand at the same time.



3 Clean the fill light

- Clean the dust on the fill light regularly to prevent overheating and burnout.
- Avoid using excessively wet towels to clean the fill light, as excessive moisture may seep into it and cause a short circuit in the electrical circuit.

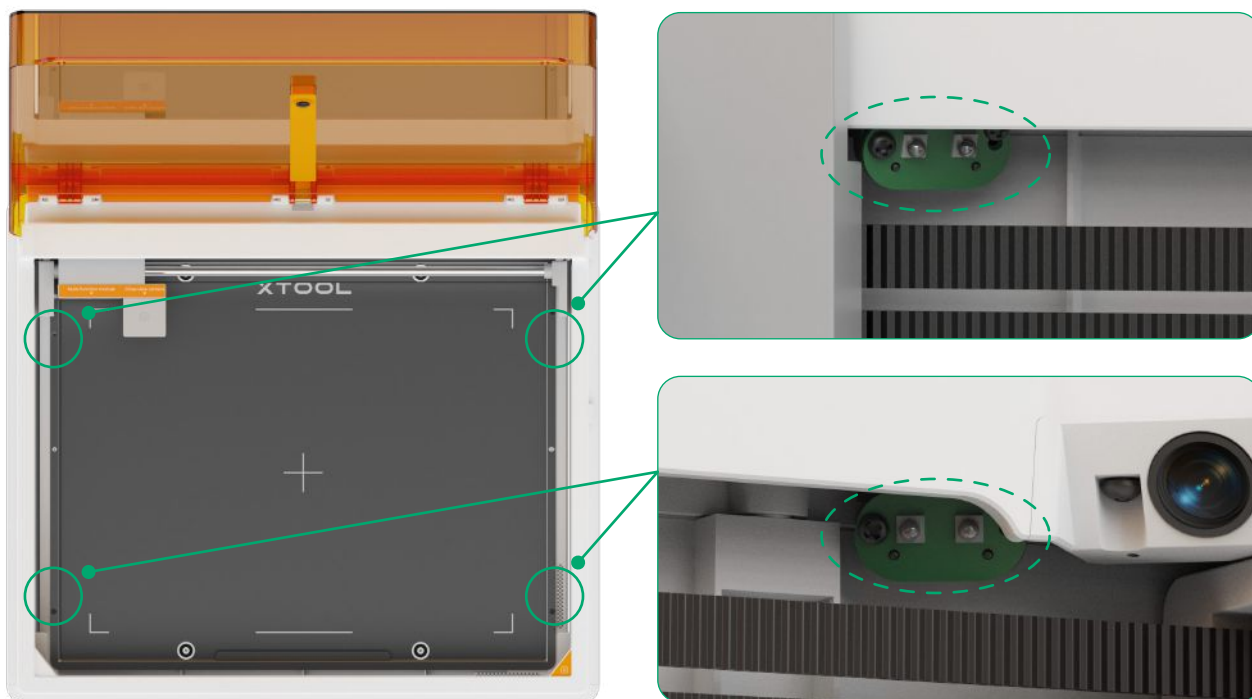

Maintain the laser module

1 Clean the lens protector and nozzle

Laser processing often produces a large amount of smoke, which may cause the lens protector to get dirty or block the nozzle. If they are not cleaned in a timely manner, the laser power may reduce and the laser module may be damaged.

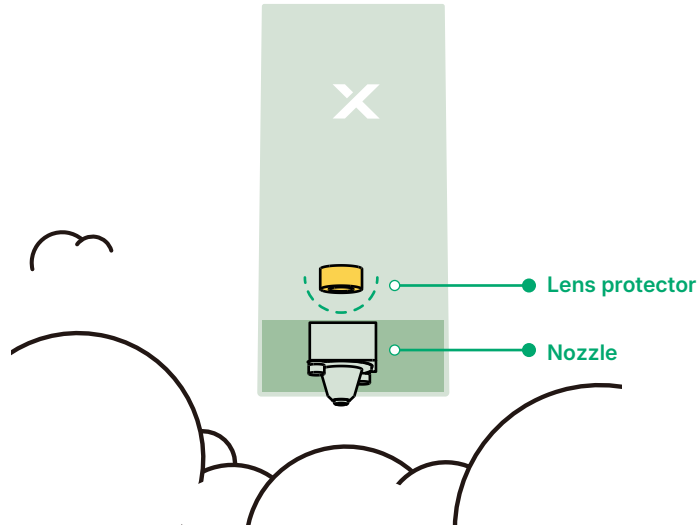

Maintenance

- **Avoid scratches:** The surface of the lens protector is fragile and may easily get scratched. When installing, replacing, or cleaning the lens protector, be very careful and avoid sharp objects contacting the protector.
- **Working environment:** Poor environmental conditions may accelerate the aging and damage of the protector. Therefore, keep the inside of the device dry without dust and corrosive gas and ensure that the exhaust fan works properly.
- **Regular check:** Regularly check whether the lens protector is installed firmly in place. If it is loose or displaced, adjust and fix it promptly.
- **Regular cleaning:** The lens protector may accumulate dust, dirt, or other impurities that reduce the laser transmission rate. You need to clean it regularly.
- **Regular replacement:** Overly worn lens protector may reduce the transmission rate of laser or even cause device faults. You need to replace it regularly based on the use of the device and the wear of the lens protector.

Cleaning steps

When the software prompts a cleaning reminder, follow the steps to clean lens protector and nozzle.

- (1) Turn off the device, disconnect the power supply, and remove the laser module.
- (2) Remove the nozzle from the laser module.

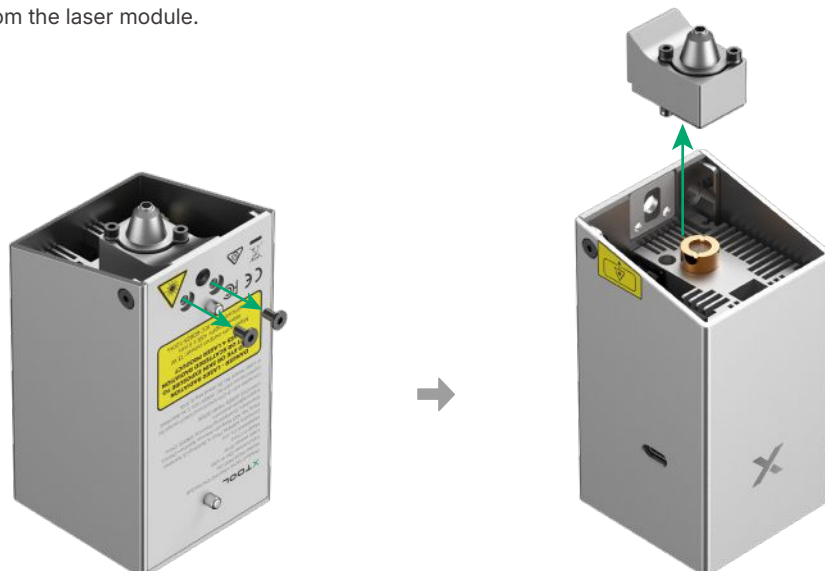

(3) Use a lint-free cloth or a cotton swab moistened with alcohol to clean the lens protector and nozzle in order.

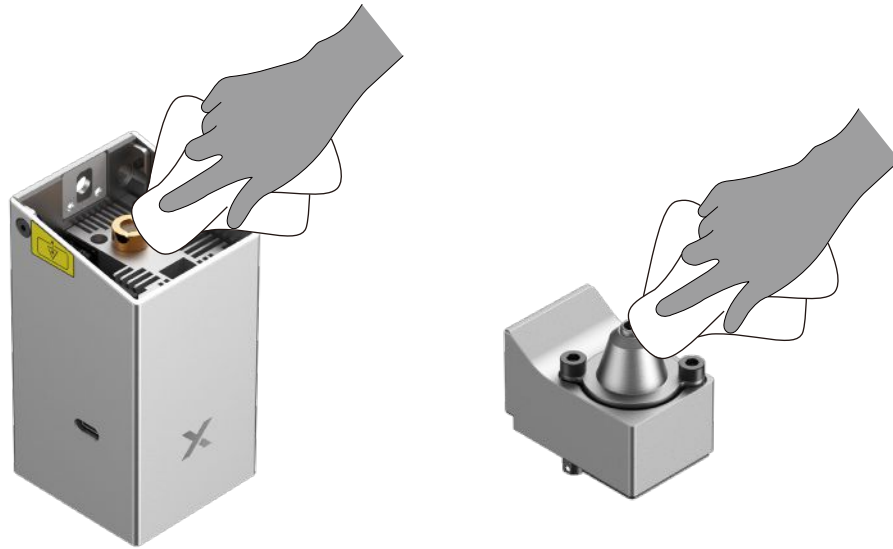

With the air assist set, you can clean the laser module at a lower frequency.

2 Clean the exhaust fan

Cleaning the exhaust fan can:

- Prevent overheating and protect the laser module. During processing, the laser module generates a large amount of heat. The fan assists in dissipating the heat, maintaining the laser module's operating temperature within a safe range. If the fan accumulates excessive dust or is clogged, it leads to a decrease in heat dissipation efficiency, and the laser module may be damaged due to overheating.
- Prevent electrical malfunctions or fire risks. Dust accumulation not only affects heat dissipation but also increases the risk of electrical failures or short circuits, particularly in high-temperature environments. Cleaning the fan reduces dust accumulation, decreases the potential risks, and ensures safe device operation.

Cleaning steps



- Ensure that you disconnect the cable from the main control board during cleaning. Avoid using excessively wet towels, as excessive moisture may seep into the device and cause a short circuit in the electrical circuit, which may damage the laser's main control board.
- Make sure to reconnect the cable securely after cleaning and avoid pulling the cable with excessive force.



Hex screwdriver

- (1) Turn off the device, disconnect the power supply, and remove the laser module.
- (2) Remove the exhaust fan from the laser module.

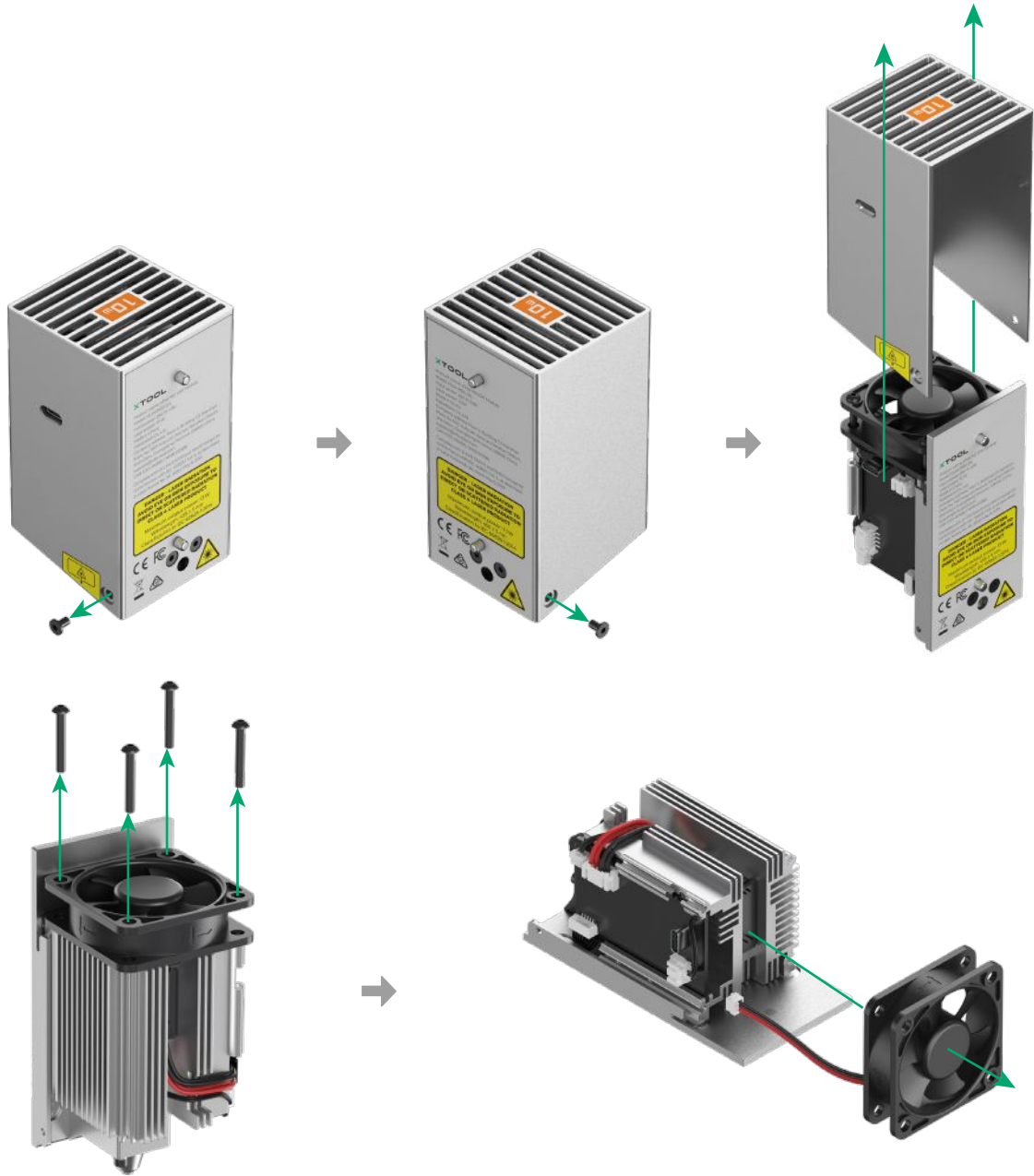

(3) Use a lint-free cloth or a cotton swab moistened with clean water or alcohol to clean the fan.

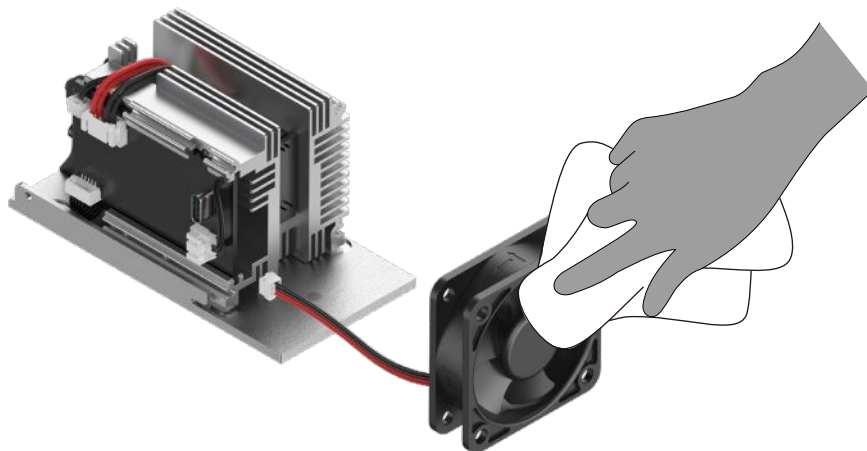

For more details about maintenance of xTool M2, visit support.xtool.com/product/93.

Use xTool M2 CMYK Inkjet Module with xTool M2

Click and visit support.xtool.com/article/2817

Use xTool Rotary Attachment 3 Lite with xTool M2

Click and visit support.xtool.com/article/2920

XTOOL